



POLICON
Engineering & Manufacturing

***Tensometric hopper weigher
for liquid ingredients
with steam heating
(Model VTM)***

Tensometric hopper weigher for liquid ingredients with steam heating (Model VTM)

Acceptance and weighing of liquid and molten softeners in the preparatory production of tire, cable, asbestos factories and rubber products factories.

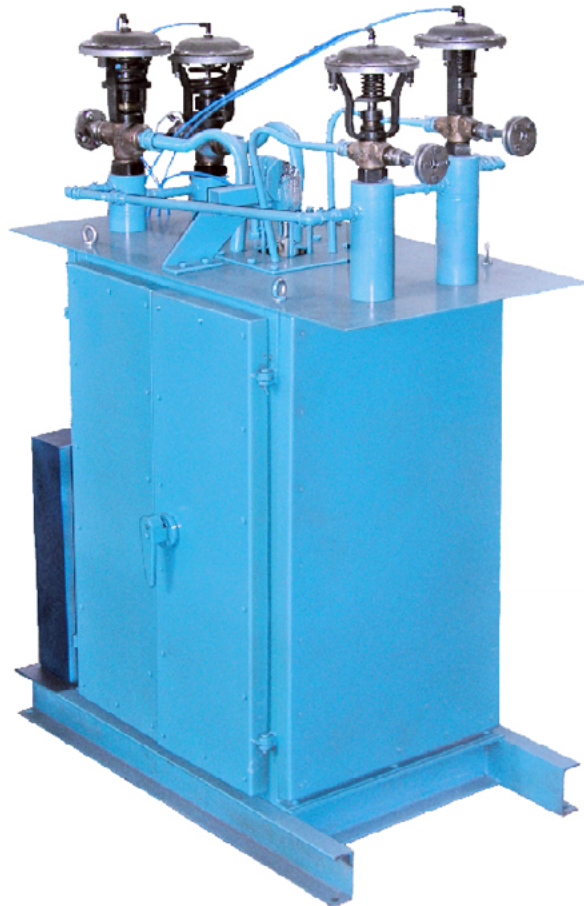

Features:

- high accuracy of weighing
- stainless steel cargo receiving device
- weighing control system based on a programmable controller
- software elimination of the influence of vibrations of the load receiving device.

**Tensometric hopper weigher for liquid ingredients
with steam heating (Model VTM)**

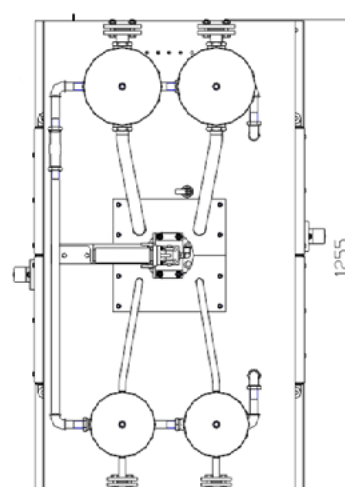
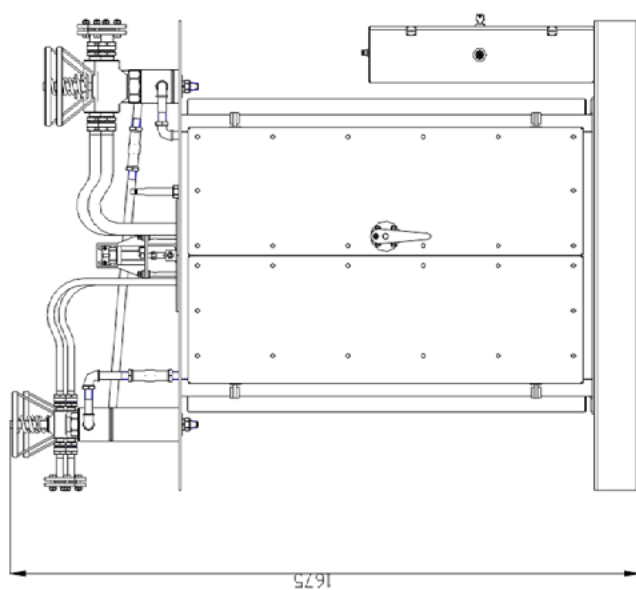
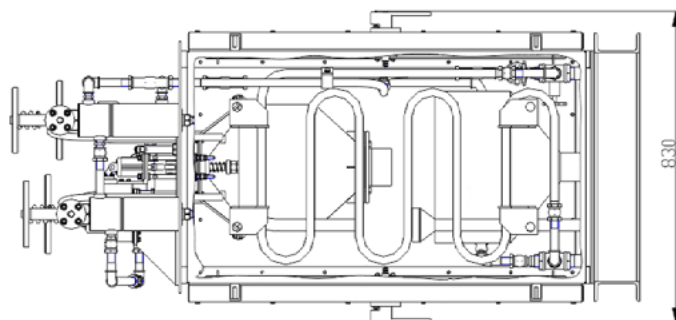

Tensometric hopper weigher for liquid ingredients with steam heating (Model VTM)

Technical Specification:

Type of scale stationary

Accuracy class0,25

Compressed air pressure in the pneumatic system, MPa 0,4 - 0,6

Steam pressure in the heating system, MPa.....0,2 - 0,3

Softener temperature, C, no more 130

Power supply:

current..... constant

voltage, V 24

Parameter Name	Model	
	VTK-15	VTK-25
Weighed material on the scales	Liquid and molten softener $\gamma=0.85-1.1 \text{ t / m}^3$	Liquid and molten softener $\gamma=0.85-1.1 \text{ t / m}^3$
Maximum weighing limit, kg	15	25
Number of weight sensors	1	1
Weighing cycle of a single component, s, no more than	30	30
Overall dimensions, mm, no more: length width height	1 255 830 1 675	1 255 930 1675
Weight, kg, no more	450	465

This product can be manufactured according to the technical specifications of the customer, taking into account its predetermined parameters and features.

Full cycle engineering services

Food Machinery

Machinery for tires, rubber, plastics manufacturing

Machinery for the chemical and oil and gas industry

Machinery for the perfumery and cosmetic industry

Modernization and automation of production

Non-standart equipment

Production of spare parts, components, assemblies

Outsourcing services - repair and maintenance of equipment

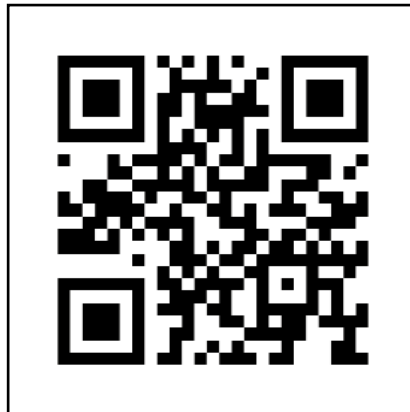

Policon JSCo

194 Lermontov Str, Omsk 644009, Russia

Tel./Fax: +7 (3812) 36 74 12, 36 74 02, 48 48 30

e-mail: info@policon-rt.ru

www.policon-rt.ru